

TL elektronik

RPM + ENGINE HOURS

TL -2812

**DIGITAL RPM, ENGINE HOURS, STOP-WATCH,
MEMORY FOR MAXIMUM AND MINIMUM
ROTATIONS WITH OTHER FUNCTIONS**

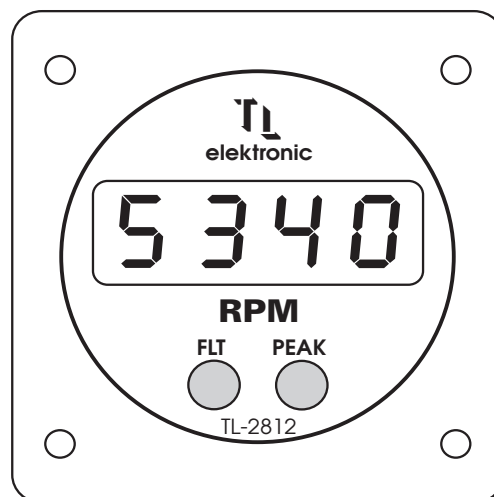

OWNER'S MANUAL

CONTENT

1.0. General description	3
1.1. Functions	
<hr/>	
2.0. RPM installation	4
2.1. Cable installation.....	5
2.2. Connection to the RPM scanner.....	6
2.3. Connection of a control light	
3.0. Testing of the RPM	7
4.0. Programming	8
4.1. Basic function programming	
<hr/>	
5.0. Function description	10
5.1. Complete engine hours	
5.2. Stop - watch and it's annulling	
6.0. Main menu description	10
6.1. Maximum measured rotations	
6.2. Minimum measured rotations	
6.3. Maximum rotations time of exceeding.....	11
<hr/>	
7.0. Annulling	11
7.1. Annulling of main menu data	
7.2. Annulling of complete engine hours.....	12
8.0. Data recalling	12
8.1. Master code setting	
8.2. Measured data displaying.....	13
8.3. Recalling data annulling	
9.0. Signalization	13
9.1. Maximum rotation signalization	
9.2. Signalization OFF	
<hr/>	
10.0 Technical parameters	14
10.1. Technical parameters RPM	

IMPORTANT NOTE !

Read this manual carefully before installation and usage to avoid damage of this equipment or your aircraft. This product is not certified as an aircraft instrument; therefore, the manufacturer is not responsible for any damage caused by its use.

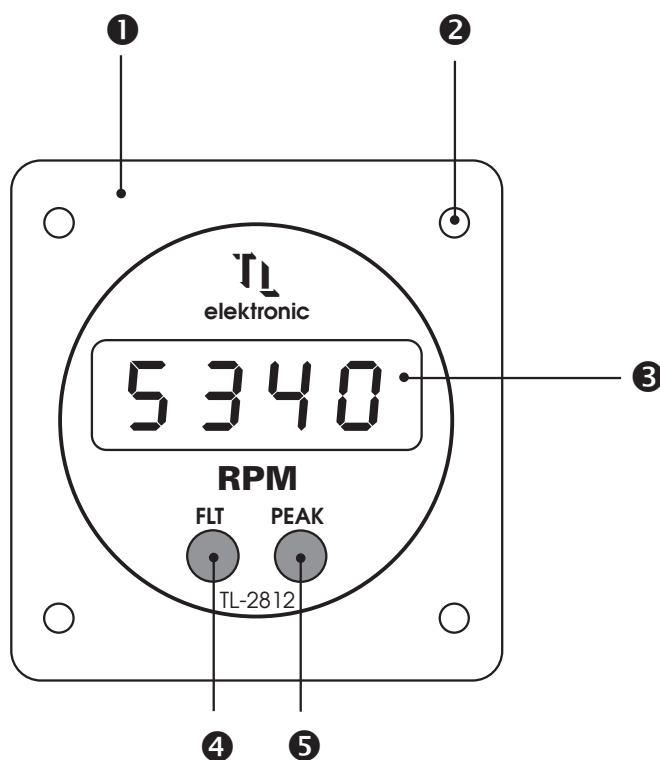

- ❶ RPM case (60 mm)
- ❷ Installation holes
- ❸ Display
- ❹ Engine hours button (discount button)
- ❺ Stop - watch button (adding button)

RPM TL-2812

1.0. General description

This product serves for measuring and calculation of rotation per minute (RPM)
It also contains other functions as engine hour, stopwatch, maximum and minimum measured RPM, signalization of exceeded RPM with a exceedance timer.

The product is build into a instrumental panel.

Data are shown on a LCD display which is well readable.

A two letter symbol is before each datum and indicates which value is measured.

Two buttons (FLT, PEAK) help set, change and confirm main menu.

All data are saved in the memory, so after a longer pause all set and measured data do not have to be entered again.

The mechanical construction is resistant against vibration, temperature changes and other weather conditions.

1.1. Functions

Main functions

Engine hours

Short-time stop-watch



Main menu (FLT)

Maximum measured RPM

Minimum measured RPM

Time of max. rotations exceeding



Setting functions

Maximum RPM

RPM for activation of engine hours

Engine connection (alternator, coil ...)

Type turn off

Setting per 10 rotations

Omitting last digit (measuring in tens)



Installation

2.0. RPM installation

Find a suitable place for the RPM in the cabin.

According to figure 1 make a hole and 4 mount holes for screws supplied with the set.

⚠ *It is important that the product is clear from direct weather condition (rain, snow...) when installed into an open-cabin aircraft.*

Install the instrument close to the view and reach of a pilot, so the LCD display is well readable and could be controlled.

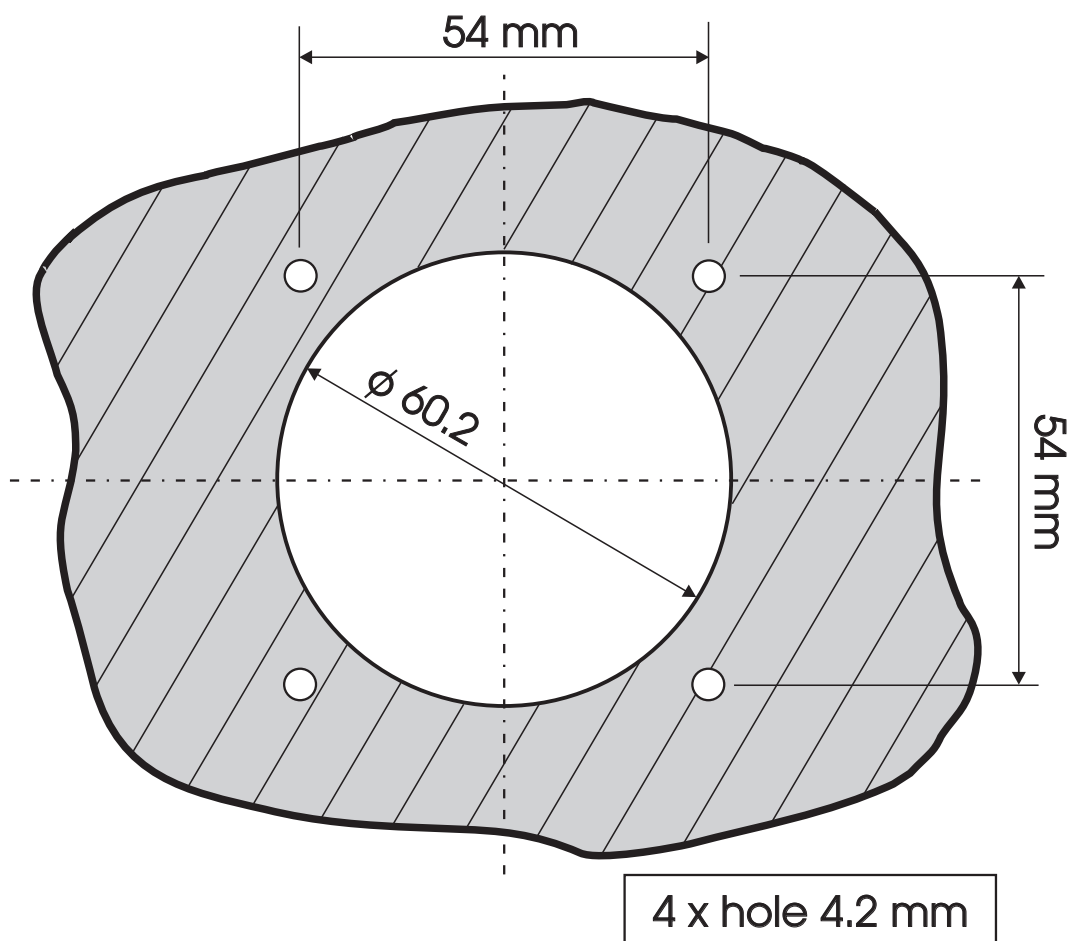

Fig. 1

■ Cable installation

2.1. Lead the cable set from the instrument to connection spots according to figure 2.

⚠ Be sure that the installation is done correctly, so any damage on the instrument and possible fire are avoided.

Tighten the cables by the band supplied in the set.

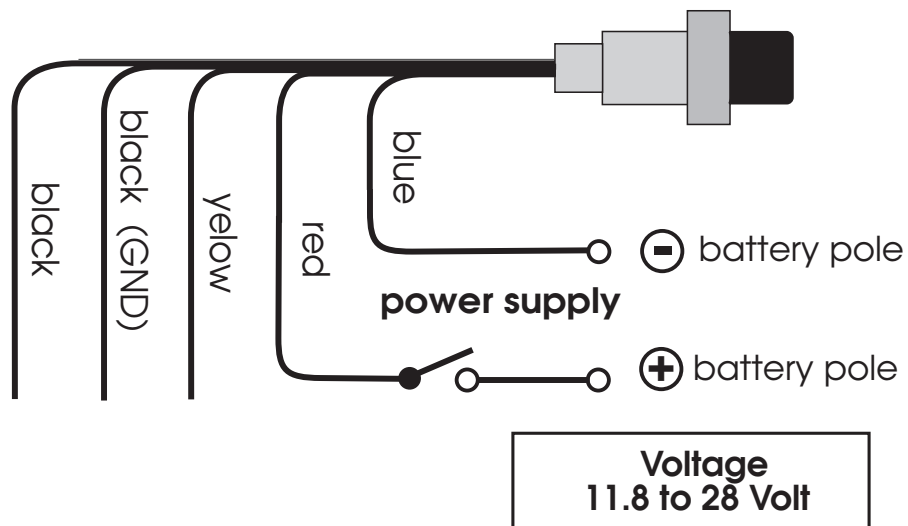

Fig. 2

The yellow cable, used for detection of switched off power supply, can be connected in two ways according to figure 3. The way of the connection depends on the way the engine is started (coil, magnetos).

i This connections is important for measuring of the minimum RPM.

If you do not require this measurement, do not connected this cable.

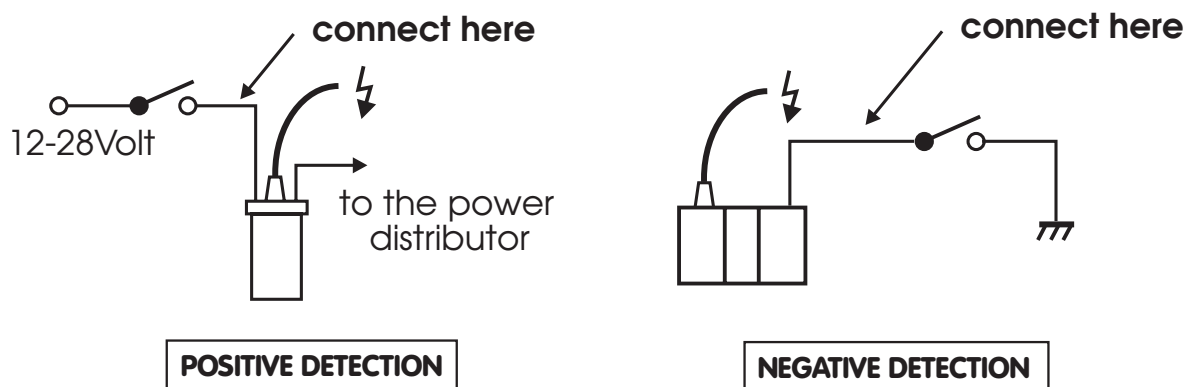

Fig. 3

Scanner installation

2.2. A rotation scanner can be an alternator, a digression of the starting magneto spool, extension of the electronic distributor unit or lone induction scanner for example in the electric starting according to figure 4., or other signal in stated voltage range.

⚠ *If it is possible for your engine, the alternator is the most suitable version. The scanner voltage can be 6 to 100 V. It is important to select a connection to an engine (scanner), which is not interfered by other signals other than those equal to rotations. Every interfering signal can be counted as a pulse by the instrument.*

If there is only one output cable for a scanner at the engine, connect it to the unmarked cable. The other **GND** - marked cable is connected to the aircraft construction.

⚠ *For the programming of the instrument, it is important which kind of voltage is on the output of the scanner DC or AC.*

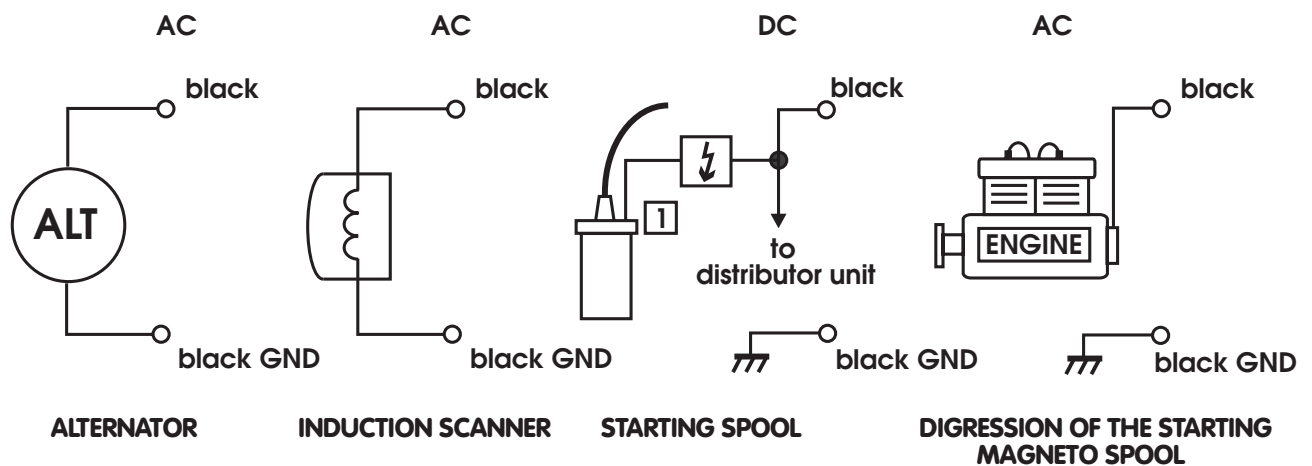

Fig. 4

Connection of a control light

2.3. Into the connector notification input a check light can be connected or this notification could be used in other ways. Switching is done to the aircraft construction.

⚠ *Voltage up to 30 Volts and current to 1A max. can be connected!*

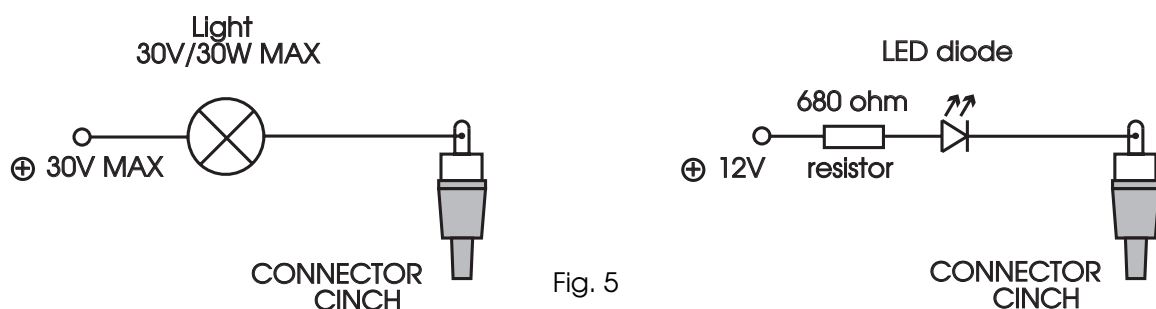

Fig. 5

■ Testing

3.0. leave the engine off

This sequence has to appear on the display

P -.-

0

- turn off power supply

This must appear

OFF

As soon as **OFF** vanishes, repeat this action.

In case everything is in the order, leave the instrument on.

⚠ *Do not turn the engine on !*

Press **FLT** and the engine hour appears:

0.0

Press **PEAK** and the stop-watch appears:

0:00

Hold **FLT** longer then 3 seconds

HI

LO

CO

In this program functions switch one after another and then return to measuring RPM.

⚠ This is the end of testing and you may start the programming.

Description of controls

4.0. Programming

A couple of data must be entered, for they are used for setting the basic configuration and calibration.

4.1. Basic function programming

- leave the power off
- press **FLT** and **PEAK** and hold then
- turn on the power
- as soon as **HI** appear release the button

Setting of maximum RPM for starting signalization (0-9999)



HI appears on the display and number 6000 appears afterwards, which is standardly set during manufacturing.

Using **FLT** and **PEAK** buttons set a number you require and by pushing **FLT** and **PEAK** simultaneously save it into the memory.

Setting RPM which will activate engine hours and stop-watch (0-5000)

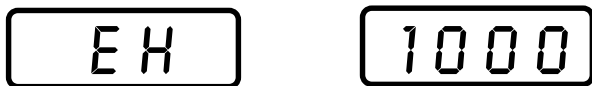

EH will appear and afterwards 1000, which is standardly set. As before set a number of RPM you require and save it.

Scanner setting (0-1)



0 is standardly set during manufacturing

According to 2.2 figure 4 find out which kind of scanner type you will use.

- for AC signal set **0**
- for DC signal set **1**

By a simultaneous push of both button save the data.

■ Programming

Turn-off switch setting (0-2)

EO

0

The value **0** is standardly set

According to 2.1 and figure 3 find out what kind of turn-off switch you are using (positive or negative signal).

- for detection with the connection to the aircraft construction set **0**
- for not-connected detection set **1**
- for positive detection set **2**

Save by simultaneous press of both buttons.

Setting the number of impulses (calibration) for 10 rotations (1-160)

LH

10

The value **10** is standardly set.

The number 10 means that one impulse equals to one rotation.

This value is implied by the number of spools in magneto, alternator (one spool = one impulse) etc.

For engines with starting spool and el. distributor the value is calculated from the number of contacts in the distributor for 10 rotations.

⚠ If you do not know the exact value for your engine, be sure to start with the highest value and then lower when testing the ideal calibration. If you do it the other way (from lowest to highest) you might get very high value. These values can be erased by using the master code (setting of the master code is described after).

Displaying type setting (0-1)

LE

0

The value **0** is standardly set.

You can set if the displaying of RPM with accuracy at tens or units.

- for full displaying set **0**
- for measuring in tens set **1** (instead of single unit there will)

Save by simultaneous press of FLT and PEAK.

⚠ This is the end of basic setting.

■ **Function description**

5.0. Basic functions:

- Complete engine hours
- Short-time stop-watch

5.0. Complete engine hours

Press **FLT**

A rectangular digital display with a black border showing the number "0.0" in a simple, blocky font.

This value shows complete engine hours and minutes h.m. (minutes in tens)

 **Complete engine hours data could be annulled and is described later.**

5.2. Stop-watch and their annulling

Press **PEAK**

A rectangular digital display with a black border showing "0:00" in a simple, blocky font.

This value shows time in hours and minutes (the longest measured time is 99h and 99min.).

 **After displaying stop-watch press once more PEAK and wait till annulling.**

6.0. Main menu description

By holding **FLT** longer then 3 sec., you will get to the main menu, where the values change after 3 sec. After the last value the instrument automatically returns to measuring RPM

6.1. Maximum measured RPM

A rectangular digital display with a black border showing the letters "HI" in a simple, blocky font.

This shows maximum RPM that have been measured since last annulling.

■ *Function description*

6.2. Minimum measured RPM



This data shows minimal measured RPM from last annulling. In case you established 1 (not connected setting) according to 4.1. in the basic setting.

6.3. Time of maximum RPM exceeding



This data shows time during which the set maximum RPM were exceeded since last annulling. The value is in seconds.

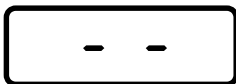

After this symbol, the instrument automatically return to measuring RPM.

 **All data in the main menu can be whenever annulled. Annulling is described later.**

7.0. Annulling

Values in the main menu and engine hours can be annulled

7.1. Annulling in the main menu

- turn on the power
- press in 1 sec. PEAK and hold it
- **as soon as CC appears, release the button !**



The symbol **CC** flashes for 3 seconds and then the instrument returns to measuring RPM. It is important that at the moment when this sign appears, the **PEAK** button is released.

■ Function description

7.2. Annulling of complete engine hours



To the annul complete engine hours data use the same technique as for annulling values in the main menu, when **CC** appears hold **PEAK** until the sign stops flashing.
After releasing **PEAK** the instrument automatically returns to measuring RPM. (when annulling the complete engine hours datum, the contents of the main menu is erased as well)

-  **When annulling main menu and complete engine hours data, all values are transmitted into so-called basket, from which could be whenever pulled out by entering the right master code.**

 -  **If the RPM instrument is supplied with engine, the producer keeps the right not to announce the master code. It helps to decide whether guarantee can be applied.**

8.0. Recalling data from the basked

The highest values are after annulling saved into inner memory where they stay 10 years after last turning off. These values can be recalled or erased by using the correct master code which is supplied with the instrument.

8.1. Master code setting

- leave the power supply off
- press and hold **FLT**
- turn on the power supply
- as soon as **0** appears and flashes, release **FLT**
- according to the code card enter the code and save by pushing both **FLT** and **PEAK**

 **At the moment the code is saved, all measured data are displayed.**

■ **Function description**

8.2. Measured data displaying

This displaying is the same as in the main menu, yet it is supplied by engine hours value which shows engine hours although the complete engine hours data was annulled in the main menu.



After the sign **HO**, **CC** flashes for 3 seconds and then the instrument returns to RPM measuring.

8.3. Basket data annulling

The annulling is the same as 8.1. Recall all the basket values and wait for **CC**, then press **PEAK** and hold it till  appears. At this moment all data are erased and you can release the button. The instrument automatically returns to RPM measuring.

 **The engine hours data is not annulled.**

9.0. Signalization

Certain conditions are signalized

9.1. Maximum RPM signalization

In case maximum RPM are exceeded, the signalization goes on and continues until the instrument is turn off.

If the maximum RPM are not exceeded, the signalization lights for 1 sec. after starting. In case maximum RPM is exceeded the signalization lasts 5 sec.



 **Signalization of maximum RPM exceeding can be turned off in the main menu**

9.2. Signalization OFF



When the instrument is turned off, the information **OFF** shows and stays for a while and signalizes the process of saving.

■ **Technical parameters**

9.0. Technical parameters

NOTE !
**Respect all the stated minimums and maximums
for flawless usage!**

9.1. Technical parameters RPM

Operating temperature	-10 °C to 55 °C
Operating voltage	11.8 to 28 V
Power consumption	15 mA (60mA-signalization)
Input voltage from the scanner	6 to 100 V AC
Output voltage from the turn switch	-5 to 30 V DC
Number of pulses for one rotation	0.5 to 16 pulse
Maximum rotation	9999 rotation/minute
Max. initialing power supply for sign.	30V, 1A
Accuracy	- 1.0%
Relative humidity	80 %
Acceleration „G“	15 G
Vibration	2 to 200 Hz
Weight	300 grams
Data saving	10 year
Material	Aluminum, dural